

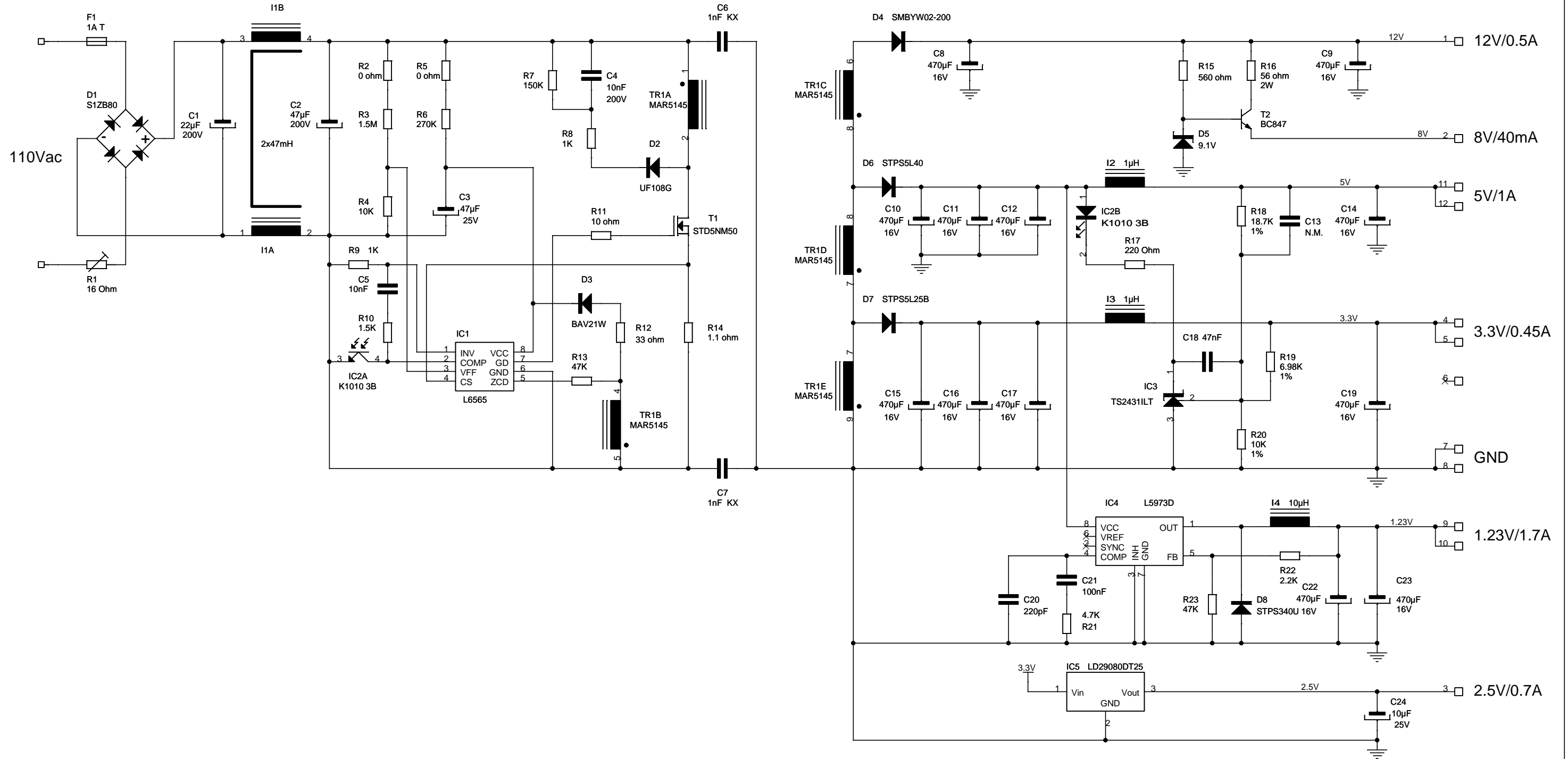

| REV. | DATE     | DESCRIPTION OF REVISION AND AUTHOR  |
|------|----------|---|
| A    | 25/10/05 | FIRST ISSUE   |
| 02   | 30/11/05 | Cambiato R4-R8-R10-R18-R19-C13-C18-C21-IC1 Mod. PCB versione V02. (agg. R23, pinout IC5,T2) |
| 03   | 19/05/06 | Cambiato codice TR1 da MAR5146 a MAR5145  |
| 04   | 24/07/06 | Modificato transistor T1 da STD7NK40ZT a STD5NM50   |



|  |                            |   |                   |              |
|--|----------------------------|---|-------------------|--------------|
|  <p>Subsystem Product Group.<br/>Use of this form is settled by ADCS<br/>procedure No.7611706.<br/>Copyright STMicroelectronics.<br/>Unauthorized reproduction and<br/>communication are strictly prohibited.</p> | <h2>SCHEMATIC DIAGRAM</h2> | Doc. ref.:<br><b>STB-CATANIA (US Version)</b> |                   |              |
|  |                            | Drawing No.:<br><b>PC789.PR4</b>              |                   |              |
|  |                            | Drawn by:<br>G.Brambilla                      | Approved by:      |              |
|  |                            | Passed by:                                    | Date:<br>25/10/05 | Sheet 1 of 1 |