

QXGA EDOF camera module

Data Brief

Features

- 3.15 megapixel resolution sensor (2048 x 1536)
- Extended Depth of Field (EDOF)
- High quality lens
- Compact size: 6.5 mm x 6.5 mm x 4.6 mm
- Video data interface - CCP2.0
- Command interface - CCI
- Analog power supply from 2.4 V to 2.9 V
- Digital power supply from 1.7 V to 1.9 V
- On-board 10 bit ADC
- Integral EMC shielding and EMI reduction techniques
- Ultra low power standby mode
- Analog Binning (2x2) for higher image quality in video mode
- RoHS (lead-free) package

Description

This data brief outlines a high performance 3.15 megapixel EDOF camera module (VX6852) for use across a range of mobile phone handsets and accessories. It is designed to be used for high quality still camera functions and also supports low power video modes. The product can output raw bayer 3 Mpixel images at up to 20 fps.

The module design is optimized for both footprint and height. The module is always in focus from 30 cm to infinity. All components are integrated inside the camera module, with the exception of two CCI pull-up resistors and a de-coupling capacitor.

VX6852 offers an ultra low power consumption hardware standby mode consuming less than 30 μ W (typ.).

A separate hardware accelerator (STV0986) or application engine (STn8815) device can be incorporated in the phone system to run the associated image processing algorithms in hardware where the baseband cannot support this processing load. The specifications of these devices are contained in a separate document.

Figure 1. VX6852 block diagram

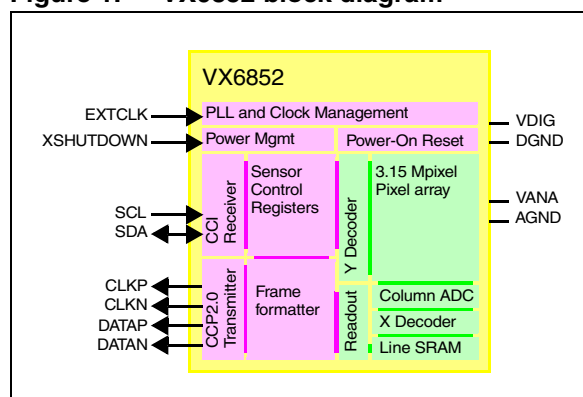
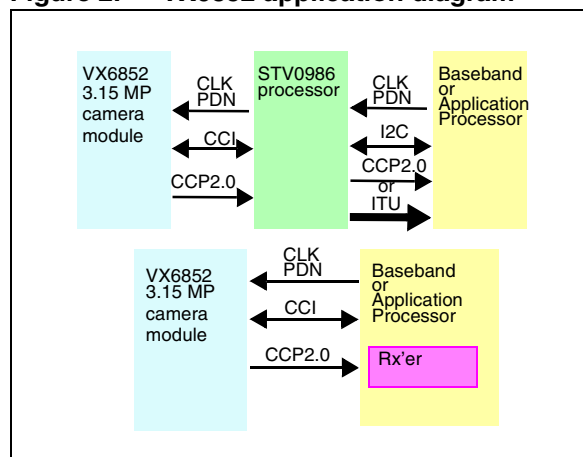

Figure 2. VX6852 application diagram



1 Technical specifications

Table 1. Technical specifications

Parameter	Description
Pixel resolution	2048 x 1536 (QXGA)
Sensor technology	ST IMG175 process
Pixel size	1.75 μm x 1.75 μm
Exposure control	+ 81 dB
Analogue gain	+ 24 dB (max)
Digital gain	+ 6 dB (max)
Dynamic range	60 dB
Signal to noise	36 dB (@ 100 lux)
Supply voltages	Analogue: 2.4 V to 2.9 V Digital: 1.7 V to 1.9 V
Average power consumption	<200 mW (Viewfinder mode) <460 mW (Capture mode)
Package size (lxwxh)	6.5 mm x 6.5 mm x 4.6 mm
Lens	58° +/-2° HFOV F/2.6
TV distortion	<-0.28%, <+0.5%
Relative illumination	40 % (typ.)
System attach	SMIA65 socket

2 Ordering information

Table 2. Ordering information

Order code	Package	Packing
VX6852Q038/T2 ⁽¹⁾	SMIA65 for socket attachment	Tape and reel

1. ECOPACK® package

3 Revision history

Table 3. Document revision history

Date	Revision	Changes
07-Feb-2008	1	Initial release.
11-Feb-2008	2	Corrected the digital supply voltage maximum value in <i>Features</i> and <i>Table 1: Technical specifications</i> . Corrected the TV distortion minimum value and the relative illumination value in <i>Table 1: Technical specifications</i> . Updated the second paragraph of the <i>Description</i> .
22-May-2008	3	Removed references to SMIA standard. Changed the F# in <i>Table 1: Technical specifications</i> .

Please Read Carefully:

Information in this document is provided solely in connection with ST products. STMicroelectronics NV and its subsidiaries ("ST") reserve the right to make changes, corrections, modifications or improvements, to this document, and the products and services described herein at any time, without notice.

All ST products are sold pursuant to ST's terms and conditions of sale.

Purchasers are solely responsible for the choice, selection and use of the ST products and services described herein, and ST assumes no liability whatsoever relating to the choice, selection or use of the ST products and services described herein.

No license, express or implied, by estoppel or otherwise, to any intellectual property rights is granted under this document. If any part of this document refers to any third party products or services it shall not be deemed a license grant by ST for the use of such third party products or services, or any intellectual property contained therein or considered as a warranty covering the use in any manner whatsoever of such third party products or services or any intellectual property contained therein.

UNLESS OTHERWISE SET FORTH IN ST'S TERMS AND CONDITIONS OF SALE ST DISCLAIMS ANY EXPRESS OR IMPLIED WARRANTY WITH RESPECT TO THE USE AND/OR SALE OF ST PRODUCTS INCLUDING WITHOUT LIMITATION IMPLIED WARRANTIES OF MERCHANTABILITY, FITNESS FOR A PARTICULAR PURPOSE (AND THEIR EQUIVALENTS UNDER THE LAWS OF ANY JURISDICTION), OR INFRINGEMENT OF ANY PATENT, COPYRIGHT OR OTHER INTELLECTUAL PROPERTY RIGHT.

UNLESS EXPRESSLY APPROVED IN WRITING BY AN AUTHORIZED ST REPRESENTATIVE, ST PRODUCTS ARE NOT RECOMMENDED, AUTHORIZED OR WARRANTED FOR USE IN MILITARY, AIR CRAFT, SPACE, LIFE SAVING, OR LIFE SUSTAINING APPLICATIONS, NOR IN PRODUCTS OR SYSTEMS WHERE FAILURE OR MALFUNCTION MAY RESULT IN PERSONAL INJURY, DEATH, OR SEVERE PROPERTY OR ENVIRONMENTAL DAMAGE. ST PRODUCTS WHICH ARE NOT SPECIFIED AS "AUTOMOTIVE GRADE" MAY ONLY BE USED IN AUTOMOTIVE APPLICATIONS AT USER'S OWN RISK.

Resale of ST products with provisions different from the statements and/or technical features set forth in this document shall immediately void any warranty granted by ST for the ST product or service described herein and shall not create or extend in any manner whatsoever, any liability of ST.

ST and the ST logo are trademarks or registered trademarks of ST in various countries.

Information in this document supersedes and replaces all information previously supplied.

The ST logo is a registered trademark of STMicroelectronics. All other names are the property of their respective owners.

© 2008 STMicroelectronics - All rights reserved

STMicroelectronics group of companies

Australia - Belgium - Brazil - Canada - China - Czech Republic - Finland - France - Germany - Hong Kong - India - Israel - Italy - Japan - Malaysia - Malta - Morocco - Singapore - Spain - Sweden - Switzerland - United Kingdom - United States of America

www.st.com