

# ZigBee® module solutions

Enabling OEMs to add wireless networking capabilities to electronic devices



Representing cost-effective and power-efficient solutions for a large variety of applications, ZigBee modules enable OEMs to add powerful wireless networking capabilities to electronic devices without the need of RF expertise and knowledge.

The devices form a family of low-power, 2.4 GHz ISM band transceiver modules based on the SN250 single chip and SN260 network processor, compliant with Zigbee/802.15.4 and EmberZNet (from Ember Corporation) meshing technology.

## Family features

- Worldwide operability in the 2.4 GHz band
- Small form factors and low power consumption
- Integrated oscillators and Murata antenna
- 3 dBm output power (5 dBm in boost mode) at the IC level
- Single supply voltage (2.1 V to 3.6 V range)
- FCC and CE compliance
- Operating temperature range: -20 °C to +70 °C
- Fully reprogrammable
- SPzB250 provides 17 GPIOs with selectable functions including UART, I<sup>2</sup>C, SPI, ADC
- SPzB260 is controlled through a standard serial interface (SPI) allowing the connection to a variety of host microcontrollers

## Target applications

- Wireless sensor networks
- Remote monitoring
- Wireless alarms and security systems
- Home/building automation
- Health, sport and entertainment equipment
- Future ZigBee systems
- Active RFID
- Machine to machine communications

The SPzB260 is based on the SN260 ZigBee network processor chip with integrated radio transmitter/receiver. This solution allows users to easily integrate the module with their own preferred application processor and development tool chain.

The SPzB250 is based on the SN250 single-chip ZigBee solution that integrates a 2.4 GHz, IEEE 802.15.4-compliant radio transceiver with a state-of-the-art 16-bit microprocessor with comprehensive hardware-supported, network-level debugging features for easy application development. The SPzB250 thus provides a complete platform capable of acting as a ZigBee coordinator, router or end device. The rich set of I/O interfaces allows integration of the module with a large variety of sensors and peripherals.

The use of the module is supported by a leading set of embedded wireless networking tools (Insight Development Kit and Jumpstart Kit) developed specifically for OEMs, and including hardware and development tools.

In order to facilitate the certification of the final product where OEM modules are integrated, every STM ZigBee module comes with FCC and CE certification.

## ZigBee module family

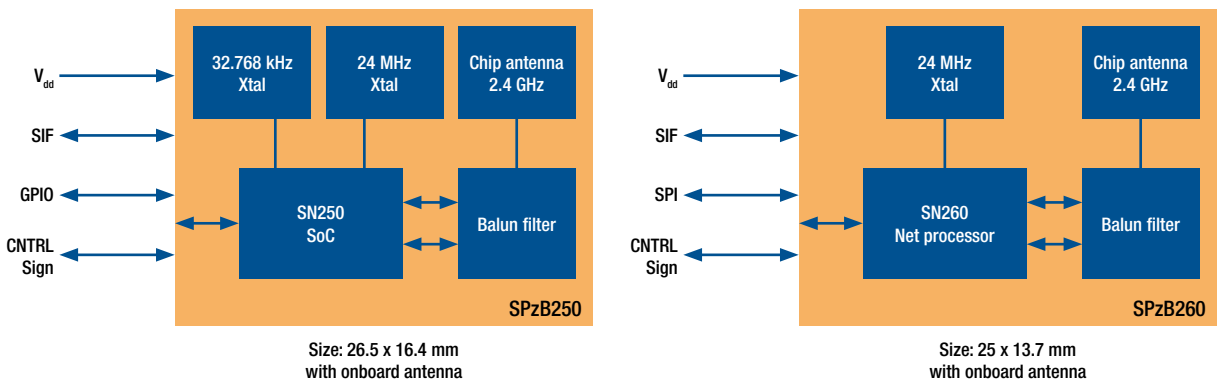

Part number	Type
SPzB250	ZigBee Module based on SN250
SPzB260	ZigBee Module based on SN260



© STMicroelectronics - February 2008 - Printed in Italy - All rights reserved

The STMicroelectronics corporate logo is a registered trademark of the STMicroelectronics group of companies. All other names are the property of their respective owners.

For selected STMicroelectronics sales offices fax:

China +86 21 52574820; France +33 1 55489569; Germany +49 89 4605454; Italy +39 02 8250449; Japan +81 3 57838216; Singapore +65 6481 5124; Sweden +46 8 58774411; Switzerland +41 22 9292900; United Kingdom and Eire +44 1628 890391; USA +1 781 861 2678

Full product information at [www.st.com](http://www.st.com)

Order code: FLZIG0308

